

8	7	6	5	4	3	2	1
No. COMPONENTS IN ASSLY	OP1	OP2	OP3	OP4	OP5	OP6	

1

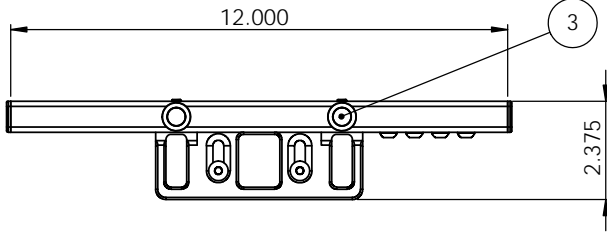

DATE ORDERED	ORDERED FROM	ITEM NO.	PART NUMBER	Default/ QTY.
		1	DS2-ZSS-OIN-100	1
		2	DS2-ZSS-OIN-200	4
		3	DS2-ZSS-OIN-300	2
		4	DS2-ZSS-OIN-400	1
		5	DS2-ZSS-OIN-500	2
		6	92015A018	4
		7	92125A240	2
		8	90799A211	4
		9	92095A224	4

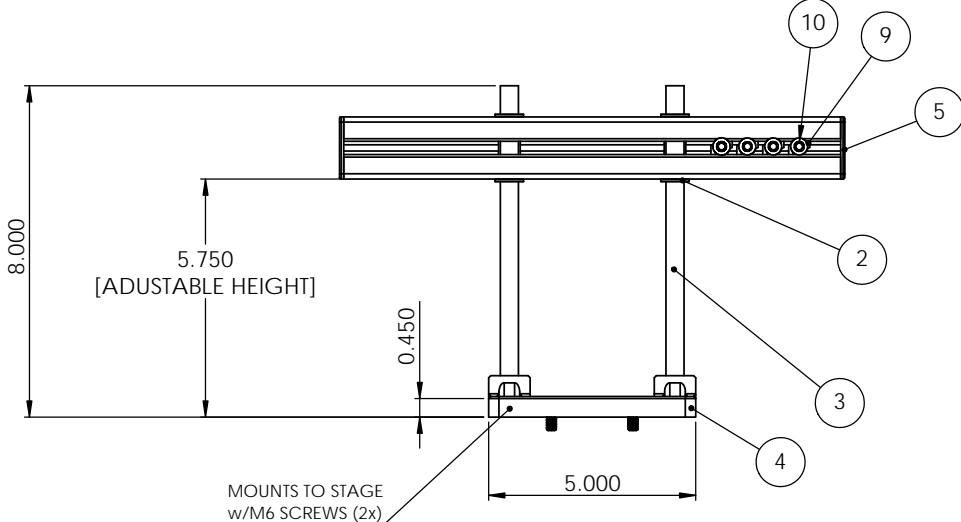

TECHNICAL DIAGRAM

PrymeFix
 fixturing solutions
 155 PRAIRIE LAKE RD, SUITE A
 EAST DUNDEE, IL 60118
 847.428.7122

3D PRINTER PROPERTIES			
Material 1:	<input type="checkbox"/> Support	Material 2:	<input type="checkbox"/> Support
Core 1:		Core 2:	

PROPRIETARY AND CONFIDENTIAL
 THE INFORMATION CONTAINED IN THIS DRAWING IS THE SOLE PROPERTY OF PRYMETECH. ANY REPRODUCTION IN PART OR AS A WHOLE WITHOUT THE WRITTEN PERMISSION OF PRYMETECH IS PROHIBITED.

REVISION HISTORY
1 ADDED LOCKNUTS AND SCREWS TO BOM, 24-0513 RD
2
3
4
5
6
7

UNLESS OTHERWISE SPECIFIED	
FRACTIONAL ± .003	No Pcs to Complete Order:
ANGULAR: ± 1.0	
TWO PLACE DECIMAL ± .010	
THREE PLACE DECIMAL ± .003	
FOUR PLACE DECIMAL ± .0005 (REAM)	
HEAT TREAT N/A	
MATERIAL Material <not specified>	
FINISH N/A	

DRAWN BY: RD	DATE: 12/13/2023
TITLE: O-INSPECT DOCKING STATION (543/863)	
SIZE B	DWG. NO. DS2-ZSS-OIN-500400
	PRINTS
REV 1	

FILE NAME
 DS2-ZSS-OIN-500400
 DIRECTORY
 P:\Manufacturing\PrymeFix Product Line\DSx Docking Stations\DS2-ZSS-OIN-500400\

8	7	6	5	4	3	2	1
No. COMPONENTS IN ASSLY	OP1	OP2	OP3	OP4	OP5	OP6	

1

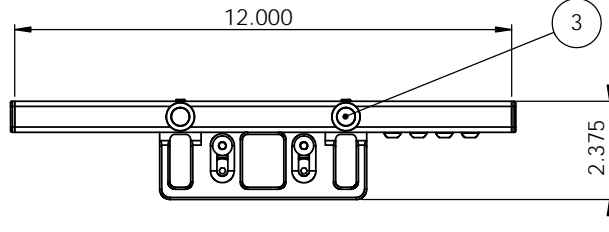

DATE ORDERED	ORDERED FROM	ITEM NO.	PART NUMBER	MAGNETIC ADAPTER/QTY.
		1	DS2-ZSS-OIN-100	1
		2	DS2-ZSS-OIN-200	4
		3	DS2-ZSS-OIN-300	2
		4	DS2-ZSS-OIN-400	1
		5	DS2-ZSS-OIN-450	1
		6	DS2-ZSS-OIN-500	2
		7	92015A018	4
		8	92125A240	2
		9	90799A211	4
		10	92095A224	4

TECHNICAL DIAGRAM

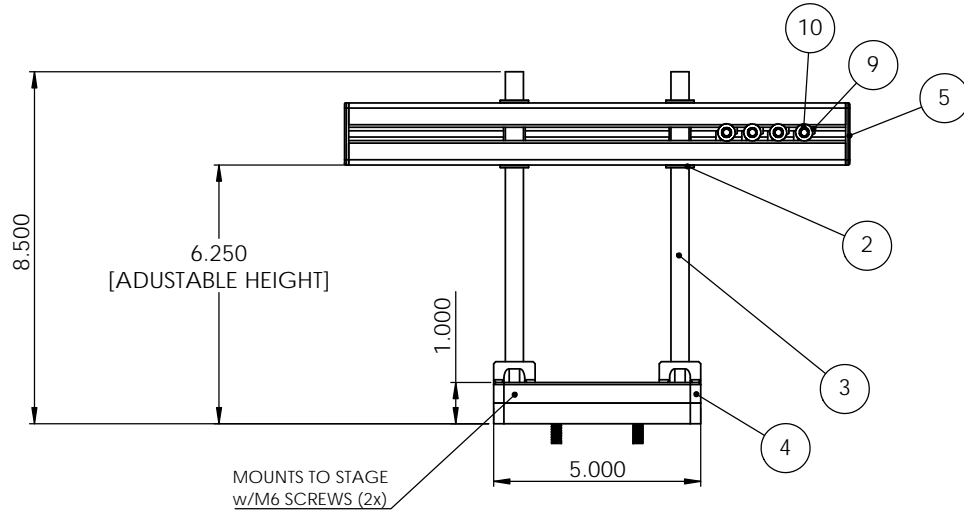

PrymeFix
fixturing solutions

155 PRAIRIE LAKE RD, SUITE A
EAST DUNDEE, IL 60118
847.428.7122

3D PRINTER PROPERTIES			
Material 1:	<input type="checkbox"/> Support	Material 2:	<input type="checkbox"/> Support
Core 1:		Core 2:	

PROPRIETARY AND CONFIDENTIAL

THE INFORMATION CONTAINED IN THIS DRAWING IS THE SOLE PROPERTY OF PRYMEFIX. ANY REPRODUCTION IN PART OR AS A WHOLE WITHOUT THE WRITTEN PERMISSION OF PRYMEFIX IS PROHIBITED.

REVISION HISTORY
1
2
3
4
5
6
7

UNLESS OTHERWISE SPECIFIED	
HEAT TREAT	N/A
MATERIAL	Material <not specified>
FINISH	N/A

DRAWN BY:	AK	DATE	12/13/2023
TITLE: O-INSPECT DOCKING STATION W/ MAGNETIC ADAPTER (543/863)			
SIZE	DWG. NO.	REV	
B	DS2-ZSS-OIN-500400	1	

FILE NAME
DS2-ZSS-OIN-500400

DIRECTORY
P:\Manufacturing\PrymeFix Product Line\DSx Docking Stations\DS2-ZSS-OIN-500400\

SCALE: 1:5 WEIGHT: SHEET 11 OF 11