

8	7	6	5	4	3	2	1
No. COMPONENTS IN ASSLY	OP1	OP2	OP3	OP4	OP5	OP6	
1							

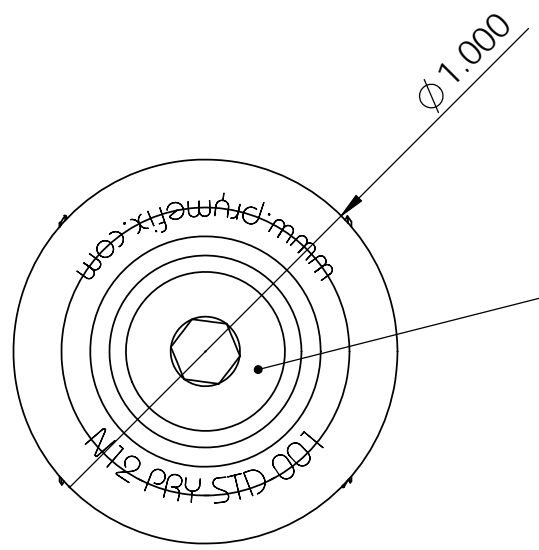

SCREW FOR MOUNTING TO MACHINE

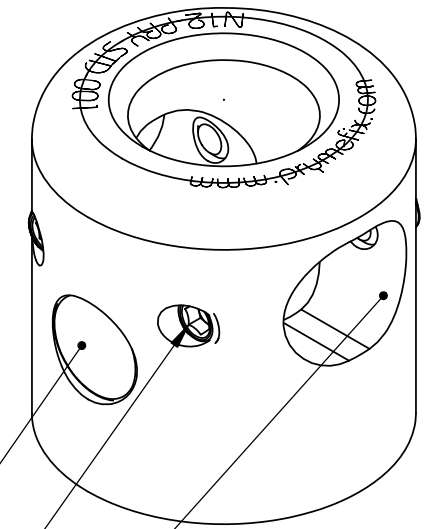

2x MAGNET FOR MAGNETIC CONTACT WITH INSERT

4x SET SCREW FOR LOCKING GUIDE RAIL

SLOT FOR GUIDE RAIL

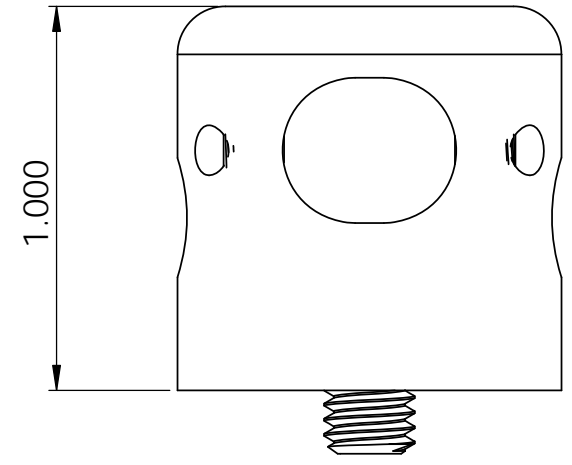

PrymeFix
fixturing solutions

155 PRAIRIE LAKE RD, SUITE A
EAST DUNDEE, IL 60118
847.428.7122

FILE NAME	N12-PRY-STD-001
DIRECTORY	P:\Manufacturing\PrymeFix Product Line\C11 & N11 Corner Inserts & Nests\N12-PRY-STD-001\

PROPRIETARY AND CONFIDENTIAL

THE INFORMATION CONTAINED IN THIS DRAWING IS THE SOLE PROPERTY OF PRYMETECH. ANY REPRODUCTION IN PART OR AS A WHOLE WITHOUT THE WRITTEN PERMISSION OF PRYMETECH IS PROHIBITED.

1		UNLESS OTHERWISE SPECIFIED	DRAWN BY:	AK	DATE	9/3/2014
2		FRACTIONAL $\pm .003$ ANGULAR: ± 1.0 TWO PLACE DECIMAL $\pm .010$ THREE PLACE DECIMAL $\pm .003$ FOUR PLACE DECIMAL $\pm .0005$ (REAM)	TITLE: N12-PRY-STD-001			
3						
4			HEAT TREAT N/A	No Pcs to Complete Order:		
5			MATERIAL 6061 Alloy			
6		FINISH HARDCOAT ANODIZED	SIZE B	DWG. NO. N12-PRY-STD-XXX Prints	REV 0	
7			SCALE: 2:1	WEIGHT: 0.06	SHEET 9 OF 12	
REVISION HISTORY			INCH UNITS			